

4 1/2" HINGE PREPARATION 1 3/4" DOORS

HINGE PREPARATION WILL TAKE 4 1/2" HIGH TEMPLATE HINGES ONLY. NON-TEMPLATE HINGES CANNOT BE USED.

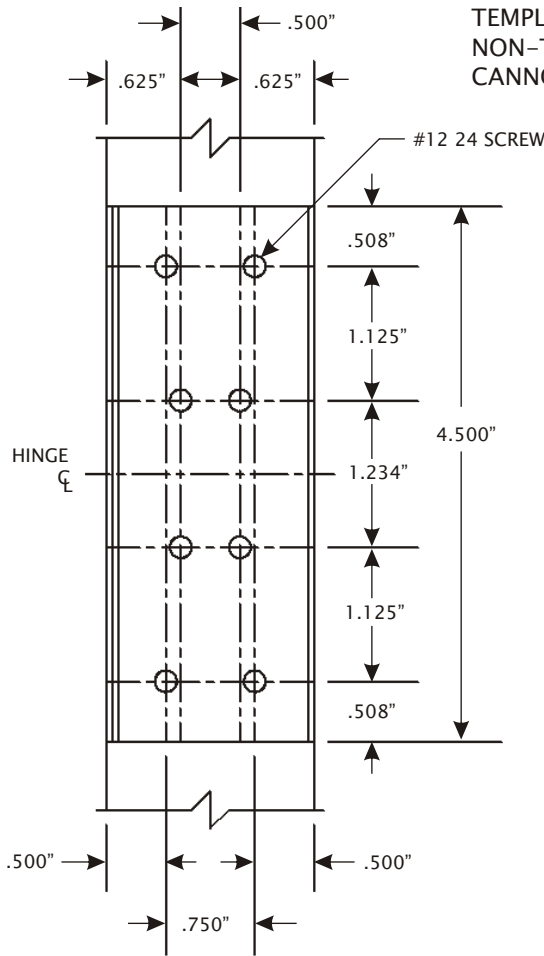

3/16" HINGE REINFORCEMENT

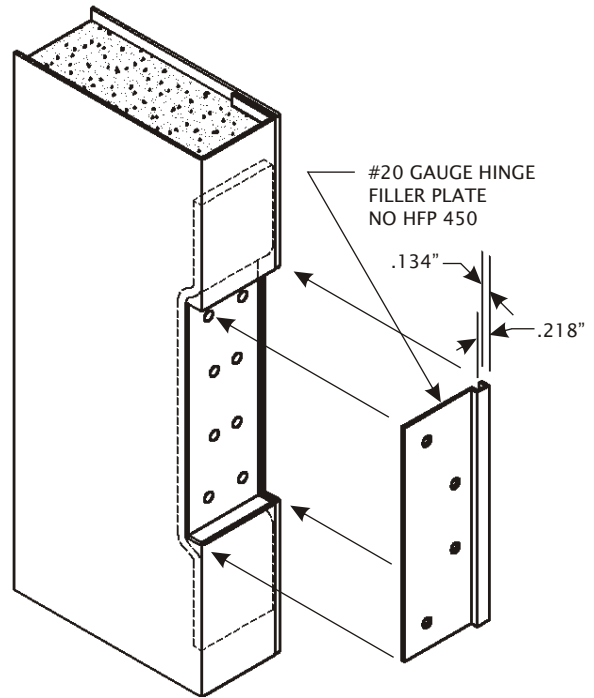
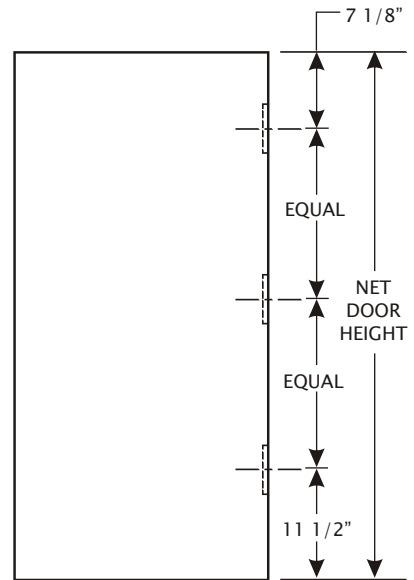

HINGES CAN BE ATTACHED ON EITHER SIDE OF THE DOOR REVERSIBLE FOR ANY HAND AND SWING REQUIRED.